



GUIDELINES
FOR
EARTHING
IN
MARITIME INSTALLATIONS

The Norwegian Electrical Safety Directorate

July 1993

1	SCOPE	4
2	DEFINITIONS	5
2.1	Main earth.....	5
2.2	Main earthing bar, main earth terminal	5
2.3	Main earthing conductor.....	5
2.4	Protective earth connection	5
2.5	Protective conductor	5
2.6	Equipotential bonding	5
2.7	Instrument earth (IE).....	5
2.8	Intrinsically safe earth (IS)	5
3	EARTHING OF SWITCHBOARDS AND ELECTRICAL EQUIPMENT	6
3.1	Earthing in explosion-hazardous areas.....	6
3.2	Earthing of main- and emergency switchboards.....	6
3.3	Connection of main earth conductor	6
3.4	Location of main earth connection.....	6
3.5	Earthing of generators and transformers.....	6
3.6	Earthing of distribution- and starter switchboards.....	6
3.7	Earthing in instrument cabinets	7
3.8	Earthing of communication equipment	7
3.9	Earthing of equipment	7
3.10	Separation of earthing systems.....	7
3.11	Earthing through fixing bolts.....	7
3.12	Earthing of cable screens	7
4	OPERATIONAL EARTHING	8
4.1	General.....	8
5	EQUIPOTENTIAL BONDING	9
5.1	Purpose.....	9
5.2	Bonding connections	9
5.3	Bonding of equipment	10
6	EARTHING OF INSTRUMENTATION SYSTEMS	11
6.1	General.....	11
6.2	Construction and installation of earthing connections.....	12
6.3	Power supplies for instrumentation systems	13
6.4	Communication between computer systems	13
6.5	Sensors.....	14
6.6	Cable screens.....	14
6.7	Shielding of equipment.....	16
6.8	Earthing in explosion-hazardous areas.....	17
7	SPECIAL CONSIDERATIONS REGARDING RADIO INSTALLATIONS	19
7.1	General.....	19
7.2	High power radio transmitters	19
7.3	Radio receivers	19
7.4	Recommendations for earthing of radio equipment	19

ENCLOSURES

INTRODUCTION

These guidelines have been prepared by a working group appointed 22 November 1990 by the Norwegian Water Resources and Energy Administration, Directorate of Electrical Safety (presently the Norwegian Electrical Safety Directorate), with the scope of preparing guidelines for earthing in maritime installations.

The group had the following scope:

"Prepare practical guidelines, within the constraints of present regulations, for the erection of operational earthing and protective earthing in marine installations (ships, mobile and fixed offshore installations). Present regulations are understood to comprise Norwegian regulations, the Rules of the Classification Societies, IEC Standards and IMO rules."

The group was appointed following the discussions at the seminar "Earthing and Earthing systems for Marine Installations" at "Teknologidagene i Rogaland 1990".

The working group has had 9 meetings, including 2 meetings for 2 days, and visited a ship and an oil platform during construction.

The working group consisted of:

Geir Bull-Njaa (Chairman)	Saga Petroleum a.s
Inge Dagestad	Norsk Hydro a.s
Helge Hermansen	Statoil
Bård Atle Hovd	Philips Petroleum Company Norway
Gunnar Klevjer	EFI-NTH
Tore Lilleskare	Aker Elektro a.s
Edvald Magnusson	BP Norway Limited U.A
Steinar Nestås	Siemens A/S
Leif Inge Nordbø	Statoil
Kåre Nærø	Ulsteingruppen

Jon Midtsund, from the Norwegian Electrical Safety Directorate has acted as secretary for the group.

1 SCOPE

These guidelines gives practical performance examples for earthing of electrical installations on board Norwegian ships and maritime installations, and on board mobile and fixed offshore installations in Norwegian waters.

The guidelines cover protective earth equipontential bonding and instrument earth. System (functional) earthing is only covered as regards the connection of the earth conductor to earth.

The intention of these guidelines are to cover ships with a hull of conductive material and mobile and fixed offshore installations in Norwegian waters.

Thus, the guidelines are applicable to all installations within the jurisdiction of the Norwegian Electrical Safety Directorate and the Norwegian Petroleum Directorate.

2 DEFINITIONS

2.1 Hovedjord

"Main earth" is the general mass of the metal hull of the ship, mobile or fixed platform.

Guidance:

The main, continuous structure of modules which are welded or otherwise having a solid, permanent connection to the main structure is considered as "main earth". For drilling modules and other parts which are not welded to the main structure are to be provided with an adequate equipotential bonding.

2.2 Main earthing bar, main earth terminal

A bar or terminal provided for connection of protective conductors, equipotential bonding conductors and conductors for operational earthing, if any, to the main earth.

2.3. Main earthing conductor

A protective conductor connecting the main earthing bar or terminal to the main earth.

2.4 Protective earth connection

An earth connection, connecting any of the following parts:

- exposed conductive parts
- extraneous conductive parts
- main earthing terminal
- main earth
- earthed point of the source of artificial neutral

such that exposed or extraneous conducting parts are put at a substantial equal potential and protecting against electric shock.

2.5 Protective conductor

A specially installed protective earth connection.

Guidance:

Protective conductor is also defined as PE-conductor.

2.6 Equipotential bonding

Protective earth connections putting various exposed conductive parts and extraneous conductive parts at a substantial equal potential.

2.7 Instrument earth (IE)

An earth connection which shall ensure earth potential on instrument systems.

2.8 Intrinsically safe earth (IS)

An earth connection which shall ensure earth potential and protection in case of failure on intrinsically safe systems.

Guidance:

Intrinsically safe earth may be combined with instrument earth.

3 EARTHING OF SWITCHBOARDS AND ELECTRICAL EQUIPMENT (Protective Earth)

3.1 Earthing in explosion-hazardous areas

In explosive atmospheres shall exposed parts in general be earthed through an earth conductor in the supply cable. Exposed parts shall in addition be provided with an equipotential bonding connected to the main earth, this connection may be through the fixing bolts or by separate earth conductor.

Exposed parts in safe areas may in general be connected directly to the main earth. For practical reasons (inspection and maintenance) should direct earthing be limited to equipment in generators-transformers-switchboards- and instrument rooms and to larger components. The user decide after practical/economical evaluations what shall be earthed through the supply cable.

3.2 Earthing of main- and emergency switchboards

Each main switchboard and emergency switchboard shall be connected to the main earth by means of a separate main earth conductor. This is to be routed the shortest, most practical route from the main earth bar in the relevant switchboard to main earth. See fig. 1.

3.3 Connection of main earth conductor

The main earth conductor is to be connected to the structure by means of a separate connection to the main earth. This connection may be a steel bar or an earth boss welded to the main earth. There shall be at least one main earth connection to the switchboards in each switchroom.

Guidance:

Precaution must be taken to ensure that the welded connection to the main earth has adequate cross section for the prospected maximum earth current. For instance it might be mentioned that a stainless steel bolt of diameter 10 mm. welded to the main earth is not adequate for installations with directly earthed neutral.

3.4 Location of main earth connection

The main earth connection shall be located such that it is not subject to corrosion or other damage, and such that it can easily be inspected.

3.5 Earthing of generators and transformers

Generators and transformers shall be connected to the main earth as stated in item 3.2 - 3.4. If the requirements of item 3.4 cannot be complied with in the area concerned, the main earth conductor is to be connected to main earth in another area, or to the main earth bar in the supply switchboard, or in the switchboard supplied from the generator or transformer. See fig. 2 and 3.

3.6 Earthing of distribution- and starter switchboard

Distribution boards and MCCs may be earthed directly to the main earth as described in item 3.1 - 3.3 or to the main earthing bar in the supply switchboard (by means of an earth conductor or screen/armour in the supply cable or by means of a separate PE conductor). Smaller distribution boards for lighting and similar should preferably be earthed through the supply cable. (However, see item 3.12 for single conductor cables and DC cables). See fig. 4.

3.7 Earthing in instrument cabinets

PE bar in instrument cabinets and similar should preferably be earthed through the feeder cable. In larger cabinets earthing directly to main earth may be applied. See fig. 4 and fig. 5.

3.8 Earthing of communication equipment

Exposed parts of telecommunication equipment shall be connected to PE earth through the feeder cable or alternatively by means of separate PE conductor. Larger telecommunication panels may have separate main earth bar for PE earth.

3.9 Earthing of equipment

Electrical apparatus, motors and similar should be earthed through the feeder cable. Larger equipment may however be earthed directly to main earth, item 3.3 - 3.5. See fig. 6.

Guidance:

Larger equipment should be earthed directly to main earth where no problems exist with regard to corrosion, other damage or inspection, (i.e. in generator room, transformer room, switchgear room, local equipment room). Smaller units located within a large area should preferably be earthed through the feeder cable in order to reduce the amount of work required for inspection and maintenance. Economical considerations should be taken when selecting earthing system.

3.10 Separation of earthing systems

The protective earth system shall be separated from earthing systems for instrumentation systems and telecommunication systems to avoid that voltage rise caused by faults in the PE system will interfere with the other systems. This means separate earth bosses, with a distance of at least 1 meter from each other. The earth conductors to the earth boss should be separated as far as possible. See fig. 7.

Guidance:

Laboratory tests indicates that the currents distribution in the structure, by single pole earth fault rise a potential related to the earth boss for the PE earth which is nearly linear up to a distance of 1 m. from the PE earthing boss. See fig. 12.

3.11 Earthing through fixing bolts

Equipment and switchboards may also be earthed through their screwed or bolted connection to structure as described in FEA-M § 1238 (except for installations in hazardous areas). In process plants, subject to the requirements of FEB §808, exposed parts are to be earthed through the feeder cable. See fig. 8.

3.12 Earthing of cable screens

Armour/screen of single conductor power cables and DC cables should not be earthed in both ends, as too large current may be generated in the screen/armour, giving too large thermal stress on the cable.

If a HF field is generated by the power cables this can be reduced by means of earthing by means of a capacitor in one end of the cable. This will block LF currents, such that thermal overheating is avoided. The capacitor is to be rated with due regard to voltage and frequency. If it is not practical to earth by means of a capacitor the power cable is to be located as close to the structure (earth) as possible. This will reduce field outside the structure. It should be noted that large fields from power cables may cause eddy currents in the structure.

4 OPERATIONAL EARTHING

4.1 General

The system earth connection (e.g. from the neutral point) is to be connected directly, or through a resistor to main earth. The system earthing connection should be kept separately from the protective earth. A common earth boss may, however be used for connection of protective earth and system earth, but separate bolted connections should be used to the earth boss. See fig. 9 and 10.

5 EQUIPOTENTIAL BONDING

5.1 Purpose

The purpose of equipotential bonding is to ensure that the bonded parts are at a substantially equal potential.

Guidance:

Equipotential bonding are to be provided for exposed conductive parts, construction elements of conductive material, pipes etc., this in order to avoid differences in potential and electrostatic charges.

5.2 Bonding connections

Direct bonding through the fixing bolts is recommended. The connection should be as described in FEA-M § 1238.

When a separate bonding conductor is used, this should be as short as possible. For HF bonding a bonding conductor with a large surface area is to be used. This must have sufficient area. The relation between width and length should be at least 1:5.

Fixing lugs for EMC filters must have metallic connection to the structure. The pin connector normally provided for earthing is not sufficient. This connection is only intended as protective earthing if a fault should occur. HF currents are to be "drained" by means of large area in contact between filter housing and structure.

The bonding connection should be of the same material as the equipment which is to be bonded. Steel connections may be used provided that they are corrosion resistant.

If other materials are used the max. galvanic potential between the different materials should not exceed 0.6 V.

Guidance:

The table indicates some potentials measured with artificial sea water:

<i>Metal</i>	<i>Potential (mV)</i>
<i>Nickel 99,6</i>	<i>+ 46</i>
<i>Brass SoMs 70</i>	<i>+ 28</i>
<i>Brass MS 63</i>	<i>+ 13</i>
<i>Monel</i>	<i>+ 12</i>
<i>Copper</i>	<i>+ 10</i>
<i>CrNi steel 1.4301</i>	<i>- 45</i>
<i>Lead Pb 99,9</i>	<i>- 259</i>
<i>Hard Chrome Covering</i>	<i>- 291</i>
<i>Steel</i>	<i>- 335</i>
<i>Cadmium</i>	<i>- 519</i>
<i>Aluminium Al 99,5</i>	<i>- 667</i>
<i>AlMgSi</i>	<i>- 785</i>
<i>Elektrolytic zinc covering</i>	<i>- 806</i>
<i>Tin Sn 98</i>	<i>- 809</i>
<i>Electron AM 50</i>	<i>- 1355</i>

5.3 Bonding of equipment

Equipotential bonding should be limited to what are strictly necessary.

To avoid dangerous potential differences between equipment and surroundings in hazardous areas, it should be ensured that the equipment has metallic connections to earth (bonding), in addition to earthing through the feeder cable. Ref. FEA-M § 1238.

Equipment connected to the protective conductor and which are connected to the main earth through fixing bolts or similar do not need separate bonding.

For equipment in hazardous areas, earthed by means of a protective conductor, but isolated from main earth, a separate bonding connection should be considered.

For isolated, non current carrying metallic parts, located in hazardous areas, and which may become charged e.g. due to static electricity, bonding should be considered. This applies e.g. to ventilation ducts.

6 EARTHING OF INSTRUMENTATION SYSTEMS (Instrument earth)

6.1 General

The intention with earthing of instrumentation systems is to ensure:

- a) supply voltage reference
- b) protection by failure
- c) that precautions against noise suppression are efficient and are not jeopardized by inadequate earthing.
Such precautions may be:
 - earthing of cabinets and enclosures
 - earthing of cable screens
 - earthing of EMC-filters

Electromagnetic noise (interference) are present at frequencies from a few Hz and up to the GHz range. If this noise enter into wires or conductor paths, a noise of undefined magnitude will be present in the system.

Even if the noise signal has much higher frequencies than the working signal, the noise power will sooner or later meet an unlinear element which will convert this into a d.c. signal. This d.c. component will be added to the working signal.

To decide precautions correctly it is, among others, necessary with exact knowledge about the following:

- the electromagnetic environmental in the area where the equipment are to be installed.
- the equipment integrity with regard to the electromagnetic compability (EMC)

Those parameters are difficult to get exactly because they will only in particular cases be analysed or measured. An instrumentation system is often built up of equipment from several suppliers which have different requirements with regard to EMC integrity.

It is very important by construction and installation of earthing connections to decide the maximum frequency of the noise source in order to achive good noise suppression. This is due to the fact that high frequency interference currents only are conducted at the surface of the conductor (skin effect). With regard to radiated electromagnetic noise will this pass through openings in the enclosure, i.e. the higher frequency require smaller openings to pass through.

With regard to the earthing connection does this mean that it is more important to install an earth conductor with large surface area rather than large cross section. In order to keep the impedance in the earth conductor as low as possible it is important that this is as short as possible.

Of practical precautions may then roughly be devided in three frequency bands which require different precautions, such as:

- a) Up to approximatly 10kHz (Low frequency)

In this frequency band the noise (interference) will be of electromagnetic nature and is mainly transmitted to the network system by inductive connections. Such fields may be caused by commutator motors etc. Capacitive noise power may also enter the network system because of commutations with high voltage pikes. (This may cause high frequency noise).

b) From 10kHz up to 30MHz (High frequency)

In this frequency band the noise power may come from power supply systems, EDB equipment and communication equipment. The electromagnetic field will be of transverse electric and magnetic nature. The noise power may enter the network system by inductive and/or capacitive connections.

c) From 30MHz and upward

In this frequency band the noise power may come from communication equipment but also from switching of inductive load by contactors. This will produce intermittent noise power in a wide frequency band. This field will be of electric nature and the noise power will enter the network system by capacitive connections.

In the following sections we will indicate earthing connection methods for a) and b), since the instrumentation systems for the time being operate in these frequency bands.

Item c) will be described occasionally only.

The present electronics in the instrumentation systems introduce little noise above the 30MHz-band, however it might be troubled by noise in particular cases. The limit at the 30MHz-band is supposed to increase upwards as new equipment for faster signal flow are introduced. The purpose with earthing in order to suppress electromagnetic noise power is to create a return path with low impedance for the noise currents so these will return to its source through paths in screens, cubicles and enclosures without entering the network signal.

An inadequate installed earthing connection may have so big impedance that the noise current will search its way back through the inductive or the capacitive paths in the network signal conductors rather than through the galvanic return path which is the intention with the earthing of screen, cabinets etc.

6.2 Construction and installation of earthing connections

The earthing connection is to be carefully installed, the connection surfaces are to be cleaned and be free from paint, grease etc. The finished connection is to be preserved in order to avoid corrosion. The earthing connection is to be protected with zinc spray and when this is dry it is to be covered with tectyl ect. Metal resistant to acids are to be used for bolts, washers, nuts etc.

Minimum one conductor is to be used for earthing of cabinets and enclosures, preferably a tinned copper band with a cross section area of min. 25 mm², this in order to ensure a large enough surface area for the earthing connection. See fig. 11.

For larger cabinets containing sensitive electronics it is recommended to install several earthing connections. In general it is recommended to install one earth connection at every meter of cabinet length. High cabinets may be earthed both on the top and at the bottom.

If desired, a separate earth bar may be used for intrinsically safe systems. See fig. 13 and 14.

The earthing connection shall be made with a separate boss welded to the steel structure. The connection must be made as short as possible because the earth connection strap also acts as an antenna, when earth currents are travelling in the strap.

Protective earth for power supplies shall be connected to a separate earthing boss welded to the structure. This is done because large short circuit currents can travel in this conductor, which again results in a potential difference between the structure and the earth connection point on the equipment, due to impedances in the earth connection strap (conductor and boss). This potential difference must not impair the function of the instrumentation systems.

If protection against high frequency noise is required (i.e. above approx. 100kHz) then protective earth shall be connected centrally in the cabinet or in the enclosure, preferably on the same earth connection as for the cabinet. This should be done to avoid that the electromagnetic noise power is flowing in or out of

the cabinet/enclosure through the earth connection. All cables entering the cabinet has to be screened, and the screens are to be connected to the cabinet at the cable entrance. This means that intrinsically safe earth conductor is to be screened even if the cable is outgoing from the cabinet/enclosure. See fig. 13.

Reference potential for the central unit is to be earthed separately and directly to instrument earth main bus-bar if desired.

6.3 Power supplies for instrumentation systems

Power supplies should have galvanic isolation between input and output in order to avoid galvanic transmission of electromagnetic noise power between the power supply and the internal system supplies. Or an EMC-filter should be fitted at the input in order to suppress the noise which is transmitted in both the common mode and the differential mode of operation. It is important to be aware of that the noise power is flowing in both directions. (I.e. up and down stream the energy flow).

The EMC-filter must be ensured a large surface contact to the cabinet/housing. This is because high-frequency electromagnetic interference current travels on the conductive surface. The filter must be arranged as close as possible to the cable entry. The guidelines for installation provided by the supplier of the EMC-filter, should be followed closely.

Connections marked with a earthing symbol are normally meant as a protective earth connection, and are hence insufficient for EMC-currents, if not connected by a copper band of adequate width.

Upon installation of computer terminals connected to a central computer, the connection of the power supply and communication cables must be studied to avoid large earth loops, through the signal conductors. If the reference potential is earthed this is the only point allowed to be earthed in the system. However, very often has the communication gates earthed potential references in which an earth loop may be created. In the same manner it might be carefully examined if there are galvanic isolation in the connections with other systems, if not there may be undecided earthing of potentials in these systems.

When coaxial cables for communication systems are used the cable screen is the return path for the signals, and if this screen is earthed to the enclosures in both systems, there will be a possibility for large earth loops.

The solution for such systems are to install a galvanic isolation or earth both systems in a common point, and the earth conductor is to be routed close to the coaxial cable. This might be a problem e.g. at communication between EDB machines or at transmission of audio- and video signals. See fig. 15, 16, 17 and 18.

Reference voltages may be connected to earth or be fully isolated from earth. In ships the reference voltages are usually fully isolated from the earth. If an additional isolation monitoring equipment is installed both on positive and negative conductors, a earth fault on one of the mains can be detected and repaired before a double fault occurs, with consequent damage to equipment.

6.4 Communication between computer systems

It is recommended to insert a galvanic isolation in the communication interface between different system.

Coaxial cables with BNC connectors should be avoided, since the outer screen also is the return path for the signal. This screen is earthed through the cabinets at both ends, which results in unwanted return paths for the signal. A earth loop is also created, which superimpose noise on the screen. See section 6.3.

The minimum requirements should be filtering in the receiver end, which isolates the screen from the connection point at the receiver. (The filter should be of the type low-pass or DC-block). Transmission cables of the type Twinax og Triax can be used, as the cable screen in these cables do not carry the signal, but acts purely to protect against EMC-radiation.

In special cases it may be necessary to use double screened coaxial cables, in which the two screens are insulated from each other, hence the inner screen is free to carry the return signal only and the outer screen act puerly as protection against EMC-radiation. In this case the coaxial cable connection to the cabinets are isolated from earth. These systems are among others used in high speed EDB-busses and in noisy industrial environments.

The communication should be of the balanced type. RS 232 is not balanced and inferior in environments where EMC can be expected. The RS 485 is somewhat better.

Fibre Optical transmission is the ideal way for signal transmissions.

The old TTY (Teletype), 20mA current loop gives also excellent protection against EMC, only exceeded in performance by the fibre optical link. TTY is also fully balanced since the transmit loop and receive loop is fully separated. TTY is better than e.g. Twinax or Triax with regards to EMC-sensitivity.

6.5 Sensors

Sensors belonging to a data acquisition system must be able to function without any voltages connected to earth with regards to power supply, reference voltages or the signal itself.

If any of these have to be connected to earth to e.g. improve the response time of NiCr-Ni elements, these must be fitted with galvanic isolators between the sensors and the computer for each sensor, since the low frequency fields will penetrate the thin foil screen.

6.6 Cable screen

The intention with the cable screen is to supress inductive and capacitive transmitted EMC noise power. Cable screen construction is in two main types: foil screen and braid screen. The supression in the individual type depend on the screen construction.

In general the following apply:

- * Braid coverage density (%-opening). The denser the better.
- * Braid angel. 45° is optimum.
- * Multilayer screen. The layers must be insulated.
- * Non-magnetic/magnetic screen material.

If the screen shall protect against Low Frequency magnetic EMC-fields from e.g. large DC-motors, large controlled rectifiers etc., the screening material must also be magnetically.

The inductive interference can easly be avoided by transposing of the supply and return conductors, then the task of the screen will be limited to supress the capacitive noise power.

Usually a screen of copper will be adequate. However since the copper screen do not cover the signal conductor 100 % it might have limited supression effect.

For weak and sensitive signals it may be necessary to use double screened cables. It is very important that the two screens are insulated from each other, if not only 6.dB additional supression are achieved. If protection against high frequency noise is desired, one of the screens shall be earthed in both ends. If both screens are earthed in one end only, it shall be in oposite ends.

The foil screen is often very thin, but it is efficient against high frequency noise fields. The foil screen gives no protection against low frequency noise, since this field will penetrate the very thin foil screen.

Cable screens should, in the central cubicle, be properly connected to a copper bar with cable shales, or by means of cable glands with extended earthing cones.

Resently a press termination was introduced on the market, this gives pressure on the cable screen as well as on the earth bar. This is suitable for signal cables with outer diameter up to 20 mm. See fig. 19, 20 and 21.

If the signal frequencies are low (typical below 10 kHz), the cable screens can be earthed at one end only, and then at the central cubicle. The other end in the process area must then be isolated to prevent accidental connection to earth. In connection boxes, the cable screen shall be transferred to the next cable isolated from earth.

Inside a connection box of plastic, the conductors lay open, and will be exposed to externally EMC. Unprotected conductor lengths should not be longer than 10 cm. Connection boxes of non-metal construction should not be used in areas where EMC can be expected e.g. power generation rooms, main switch boards, motor controls, power cables etc.

Today the cable screens are earthed mostly at one end, but the ever faster computers might in the near future result in the connection of the cable screen at both ends, especially for the communication systems.

If the cable screen is earthed in both ends a suppression of the inductive noise power is achieved. The screen will together with the earthed structure form an earth loop through which a current will flow, this current is proportional with the electromagnetic field which induce this current. This loop current in the screen again generate its own field with opposite direction and hence, attenuate the external electromagnetic field.

It is important to be aware of that the earth loops only can impose noise power if the loop consist of a signal conductor with a working signal.

The philosophie with regard to the earthing methodes for the screen may vary from one supplier to another. One supplier recommend to earth the screen of the cabinet entrance. See fig. 20. Another supplier recommend to bring the screen as close to the equipment as possible. See fig. 22. It is very important to be aware of such divergencies in philosophie particularly by modifications of installations.

6.6.1 Cable separations

Cables with signals of different energy levels should be separated by distance. Signal cables can also be EMC-sources. 230 V ac signal cables to e.g. motor-contactors and solenoids etc., must be separated from 24 V dc, 4-20 mA, 0-10 V dc etc. signals, and from telecom and loudspeakers.

The following distances for cable separation is recommended:

- Between screened cables with different signal levels - 250 mm.
- Between non screened cables with different signal levels - 500 mm.

The above apply to parallel cable runs up to approx. 50 meter.

Guidelines for cable separation are to be found in the following documents:

- DnV A/S report 80/P008
- EFI report TR2544, 1980
- IEE 518-1982
- Some military requirements

Parallel run of high- and low voltage cables does not normally affect the signals, however in cases of single pole short circuits, large voltages may be generated in adjacent cables.

Cables closer than 3 m. from radio/radar masts shall be protected in seamless steel pipes in order to reduce the interference.

6.7 Shielding of equipment

The shielding in a system consist of cable screens and equipment enclosures. It is therefore important that screens and enclosures are correct connected.

The termination of the cable screen to the enclosure may be performed after various methodes. Some methodes are shown in fig. 19 and 20. Common for all cable terminations are that the screen must have good contact all around the surface, this gives two adventages:

- no openings at the cable entrance.
- no electromagnetic noise currents are circulated in the enclosures.

Cable screens which are terminated by use of "pig-tails" should be avoided in low frequency systems. The use of "pig-tails" has the following two disadvantages:

- the area of the cable screen will be very much reduced, hence it can not protect against noise currents above a few kHz, and consequently it do not act as an adequate noise absorber.
- the strong low frequency noise currents will be conducted by the "pig-tail" to earth and will then form a parallel path to the unprotected signal conductors.

By the use of "pig-tail" shall the cable screen be connected to earth outside the enclosure, or the cable screen are to be connected internal in the enclosures as soon as possible. By design of enclosures several applications are to be considered:

- the electromagnetic environment where the enclosure is to be located
- the frequency band from which it is to be shielded
- the EMC-integrity of the equipment in the cabinet
- the material in the enclosures
- the thickness of the material
- the cut-outs for instruments, covers etc.
- conductive gaskets

By noise generating equipment and by susceptible equipment for electromagnetic radiation the better the cabinet must be designed with respect to shielding. E.g. all around welded constructions and conductive gaskets are to be used in doors, covers, cable transits etc. In particular cases it is necessary to shield behind front mounted instruments etc.

If shielding against strong low frequency fields are desired, then the enclosure material has to be of a certain thickness and it shall be magnetic with a high permeability. For steel sheets are 1 to 2 mm. thickness adequate. Enclosures of plastic, sprayed with metal or that like are not adequate. In particular circumstances, e.g. by coloured windows etc. it might be necessary to use material with very high permeability, such as My-metal, VACOPERM_{tm} etc.

An electromagnetic field will roughly pass unsupressed through openings in the enclosure, the penetration depth is equal to the lenght of the diagonal of the opening. This may be critical at doors and covers. If the requirement to the shielding is above medium, approx. 40 dB noise supression it may be necessary to use conductive gaskets in doors et.

Equipment and internal wiring are to be located away from the openings.

For equipment located in the same area it may be evaluated if these are electromagnetic compatible with each other. The simplest form of shielding against EMC-noise is to arrange with adequate distance between the various equipment. It is also to be considered that some equipment may radiate noise power in a frequency band distinct from its own susceptible frequency band and hence make disturbensies to other equipment. It shall be noted that it is easier to shield against incoming electromagnetic noise from e.g. electrical switchboards, panels etc.

6.7.1 Engine room, engine control room, holds

It is not necessary with extensive shielding requirements in the engine room or in the engine control room of steel vessels if no EMC-emitting equipment are arranged close to openings of the engine- or engine control room. Today normal steel-/aluminium cabinets for maritime use provide ample shielding if the cable entries are provided with cable glands with extended earthing cones or likewise. However it is important that screened cable entries are correct installed. Further, if the cabinet contain electronics it shall not have more than 50 % cut-outs for instruments etc.

6.7.2 Bridge, computer rooms, superstructure, radio rooms

In EMC-noise filled areas, such as bridge, sonar rooms etc., EMC-tight cabinets with welded side and back sheets should be used to prevent EMC interference to/from radio, radar etc.

Openings up to 72x72 mm can be accepted as the EMC-field penetrates the cabinet openings unattenuated up to approx. a distance equal to the diagonal of the opening. This is correct for EMC frequencies up to about 100 kHz. Equipment which is very susceptible to EMC must not be arranged close to such openings. EMC fields with higher frequency than 100 kHz penetrates deeper into the cabinets.

Large removable opening covers must be ensured a very good electrical connection over a large area to the cabinet by use of EMC-gaskets or wide bonds.

EMC-gaskets should be considered where large doors, hatches or panels are to be provided. An even pressure around the openings must be provided. The cable entries should be made with cable glands with extended earthing cones or EMP/EMI multi cable transits. See fig. 23.

By earthing of cabinets it shall be ensured that also the cable entry plate have good earth connection. (Often are the cable entry plate isolated from the cabinet by rubber gaskets). All cable entries should be through individual gland in the bottom of the cabinet.

Superstructures are often of aluminium and bolted to the hull. This gives often a poor connection between the superstructure and the hull since these are isolated from each other due to corrosion requirements.

To improve the connection between superstructure and hull, e.g. a 10 cm wide CupAl-bonds can be used every 10 m.

6.7.3 Especially sensitive equipment

Especially sensitive cables with signals in the range μ A, μ V, mV etc., should be installed in steel tubes past EMC-critical areas such as radio rooms, power station, antennae foot points etc.. Seamless tubes with bends of pull boxes must be used. This is especially critical for cables going to/from the sonar, dynamic positioning system, echo sounders, alarm- and control-systems with the above mentioned signal levels.

Cables should be routed away from large earth conductors belonging to radio transmitters and any conductors for lightning-arrestors.

6.8 Earthing in explosion-hazardous areas

In explosion-hazardous areas, the earthing will have to be carried out considering the risk of ignition of explosive gases or liquids.

This means that earth-loops can be made of the signal conductors, when a zener diode burns through to earth. This again can lead to a malfunction of the signal involved due to the induced EMC-currents in the earth-loop.

If earthing according to rules for Ex installation does not satisfy the need to EMC-screening, a double screened cable can be used.

The inner screen must be treated according to Ex-rules, but the outer screen can be treated according to what is necessary to achieve good EMC-screening. The outer screen can e.g. be earthed at both ends to protect against High Frequency EMC-fields. See fig. 24.

Another method, and far better, to solve the problem with earthing of Intrinsically Safe circuits, is the use of signal converters incorporating a galvanic separation.

7 SPECIAL CONSIDERATIONS REGARDING RADIO INSTALLATIONS

7.1 General

On communication systems it is usually the frequencies between approx. 150 kHz and up to 30MHz it is necessary to take precautions for with respect to the noise power suppression.

It is therefore very important that the earthing of radio installations is carried out correctly to ensure correct function of the equipment, and safety of personell.

7.2 High power transmitters

High power transmitters radiates high effects from antennas. This effect will have to return to the output stage of the transmitter through the structure which will be the earth plane for the transmitter. The current density around the antenna foot and the earth connection of the antenna tuner is therefore high.

The earthing of the output stage will have to be given special attention to ensure a proper return path for the antenna current. This current is of High Frequency, which means we need a large area to earth, properly cleaned. Ineffective earthing of the output stage means that the currents needs to find alternative return paths to the output stage, which could be capacitive coupled through power leads etc. of other equipment. This will again set of fire alarms, intercom systems etc. due to unwanted currents in these systems. The radiated power from the transmitter will of course also be reduced.

Radiated emissions from radio equipment can disturb equipment like computers, sensors, fire alarm, navigation equipment etc.

7.3 Radio receivers

Radio receivers are very sensitive to high frequency radiation.

To achive sufficient distance to noise susceptible/generating equipment may low power transmitter/receiver antennas be located in separate antenna towers provided with local earthing in order to avoid long earth connections.

The antenna tower will have to be earthed to the structure with appropriate earthing bonds with large area. Preferably the tower should be welded to the structure.

EMC-generating/propagating cables should be arranged as far away as practical from receivers cables, preferably in steel tubes, due to the high sensitivity of the receivers.

7.4 Recommendations for earthing of radio equipment

MF/HF transmitters shall be earthed directly to the structure by means of wide copper bonds ensuring a large surface contact.

All earth connectors must be made as short as possible, and the output stages of the transmitters must be arranged as close as possible to the antennas.

A long earth conductor can act as an antenna, and radiate EMC to other systems.

Where vibration is to be expected, the earth connection should be welded.

High Frequency radiation can induce dangerous voltages in cables or structure parts close to the antennas. When instrumentation cabling is planned the distance to and power of radio antennas must be observed. If the necessary distance can not be achieved, such cables must be arranged in steel pipes.

Protective earthing

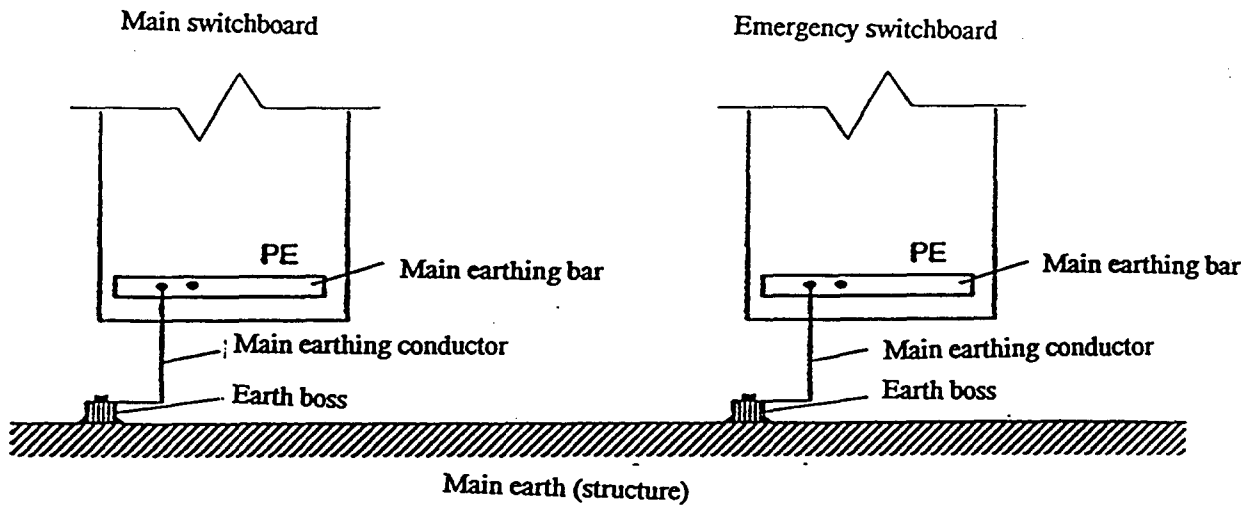

Figure 1

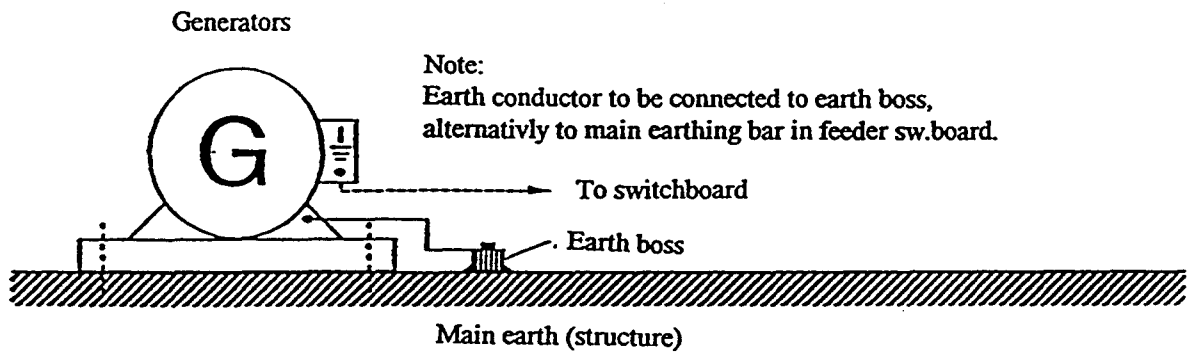

Figure 2

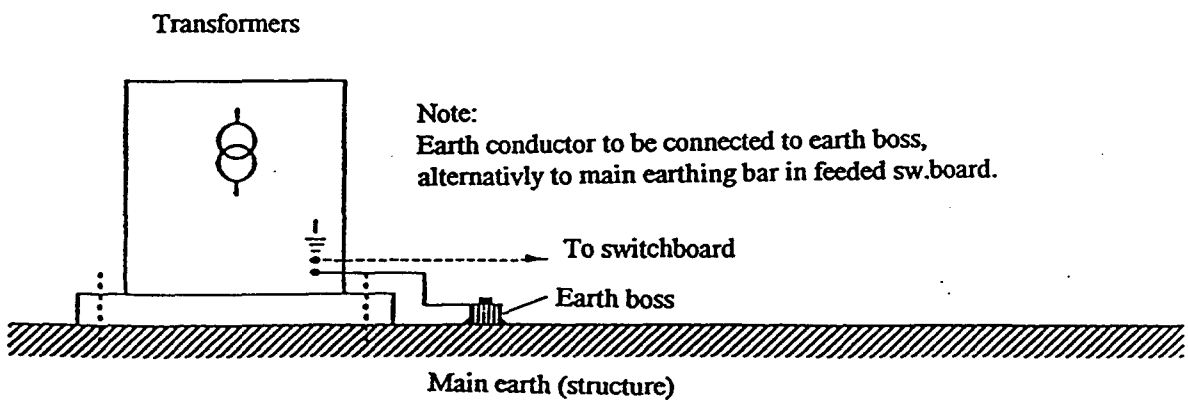
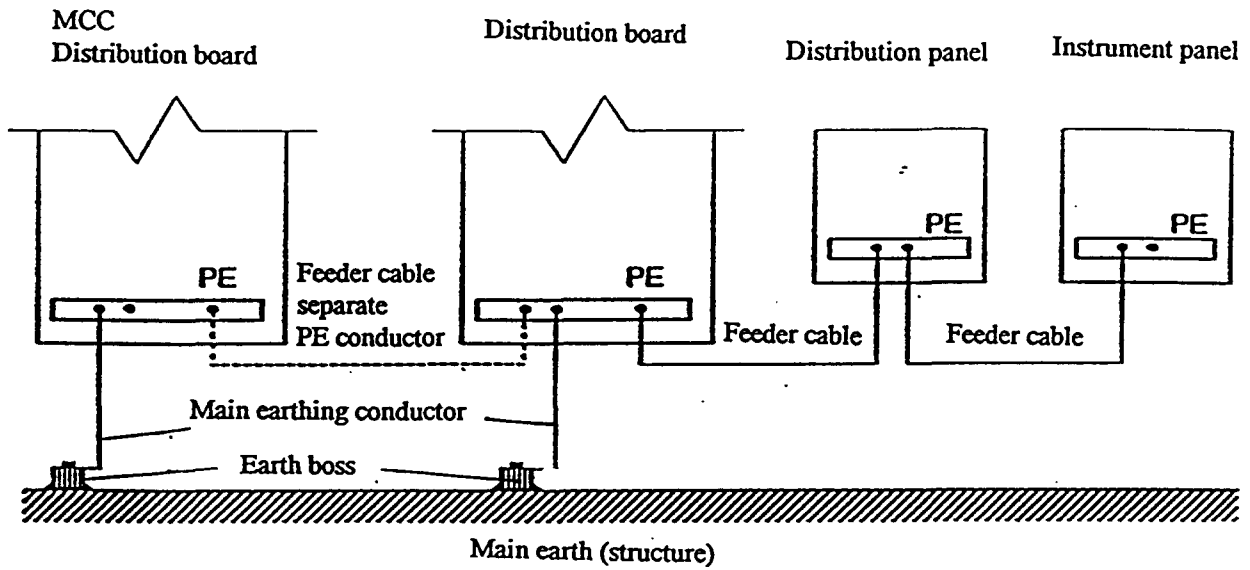

Figure 3

Protective earthing



..... Alternative connection

Figure 4

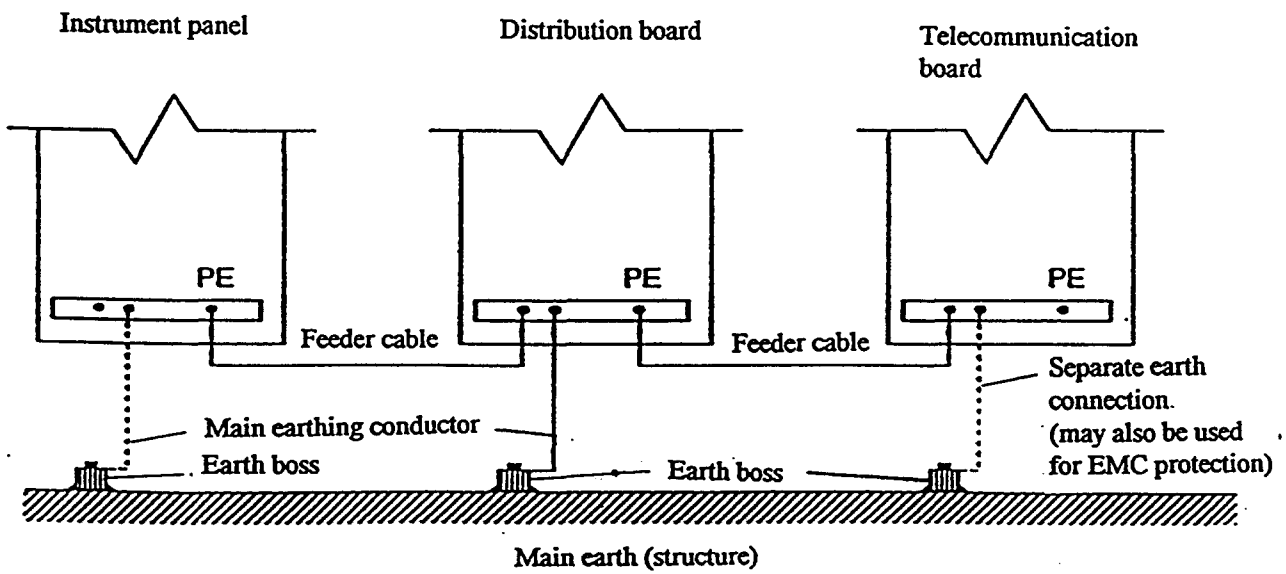

..... Alternative connection

Figure 5

Protective earthing

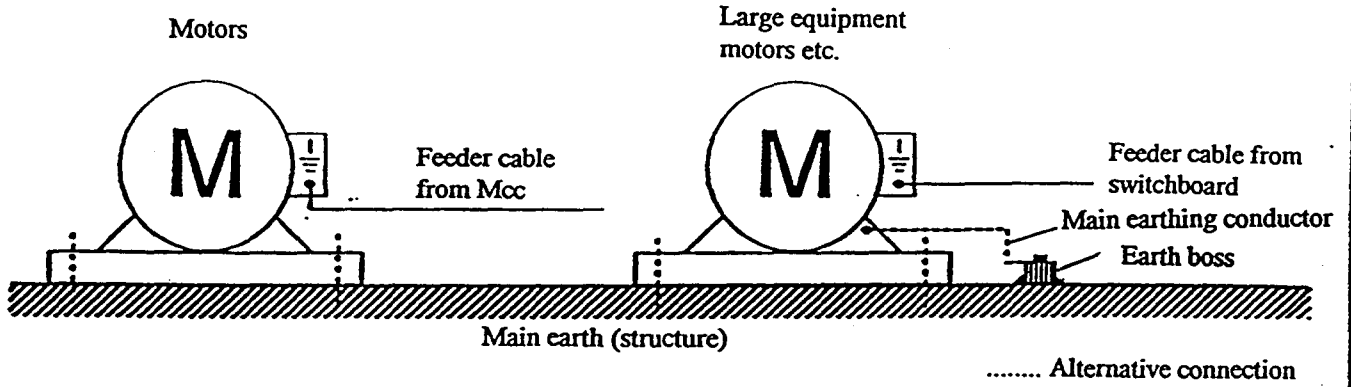

Figure 6

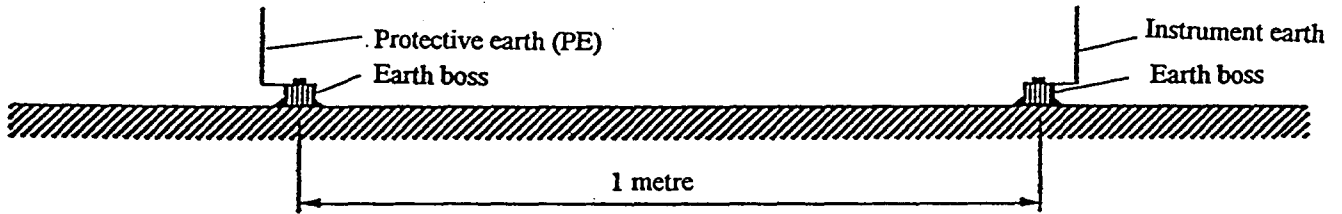

Figure 7

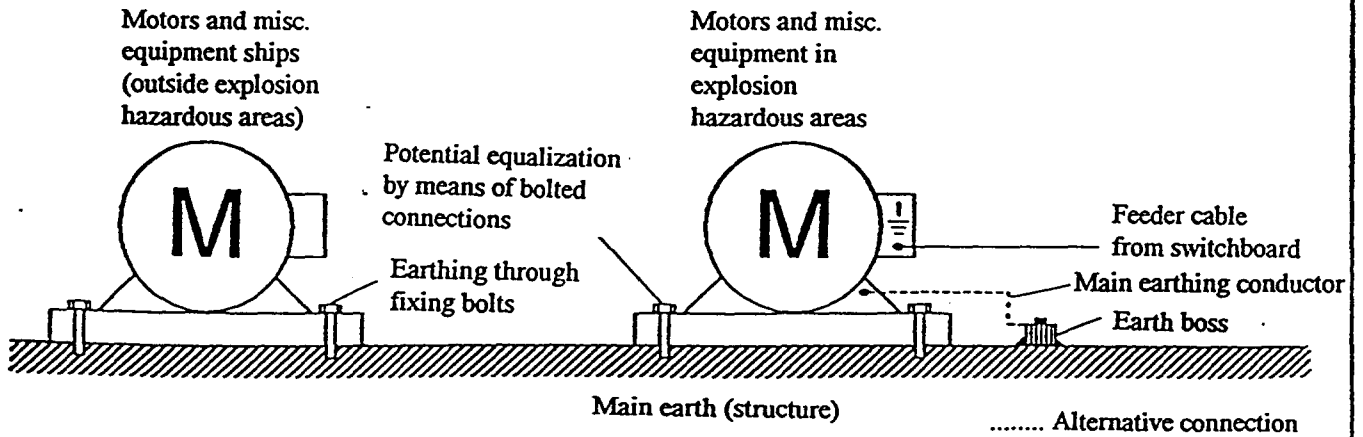

Figure 8

Operational earthing

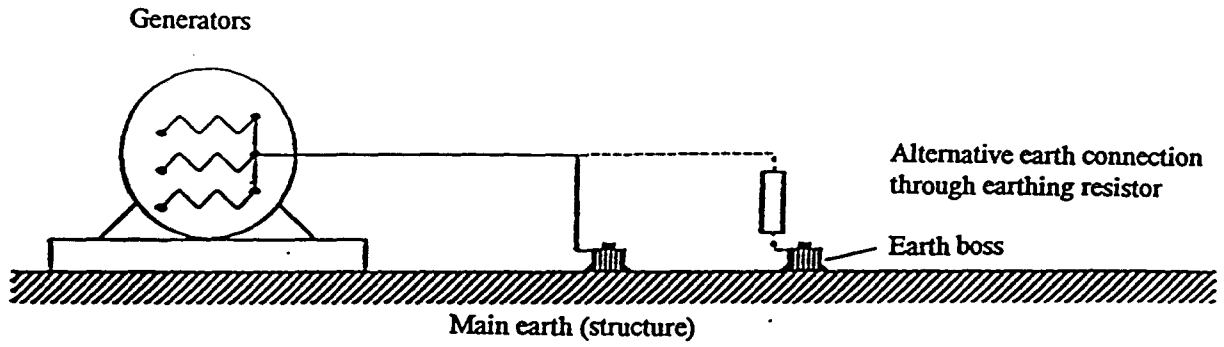
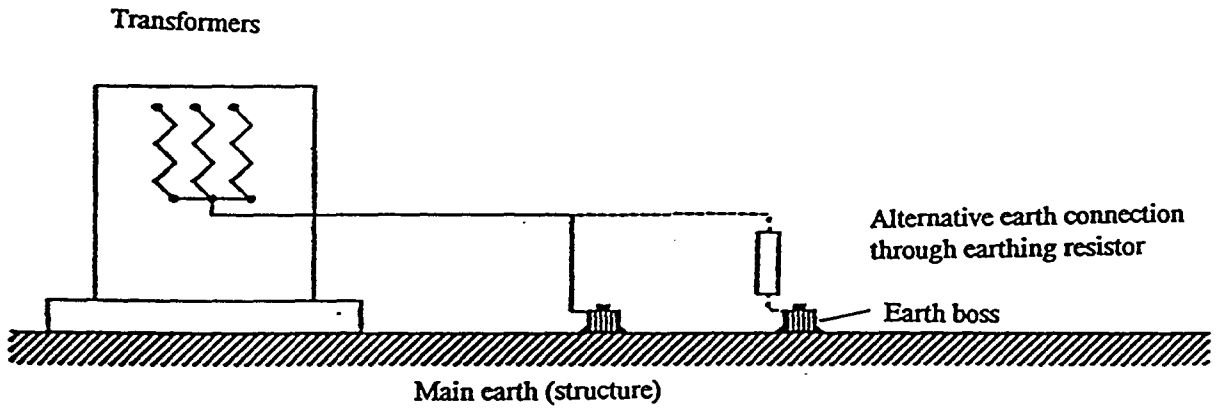

Figure 9



..... Alternative connection

Figure 10

High frequency bonding connections

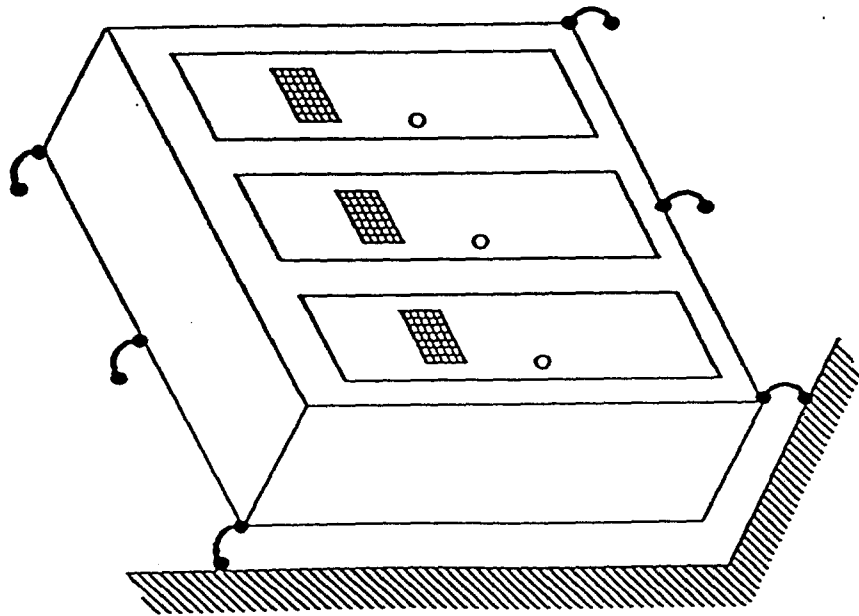

Earthing of cabinets

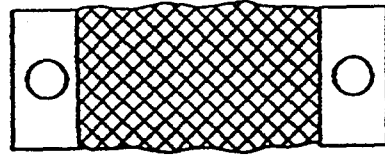

Earthing conductors

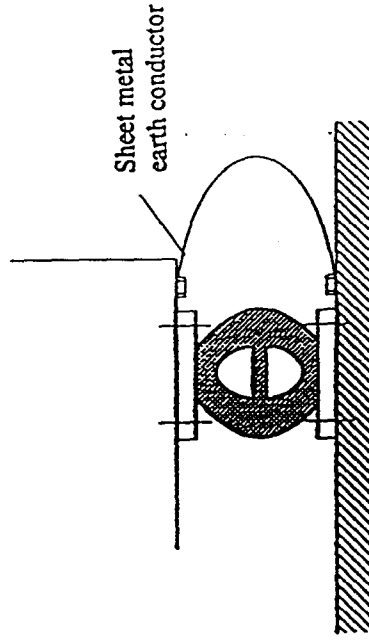

Earthing in case of vibration dampers

Figure 11

Distance between PE earth boss and IE earth boss

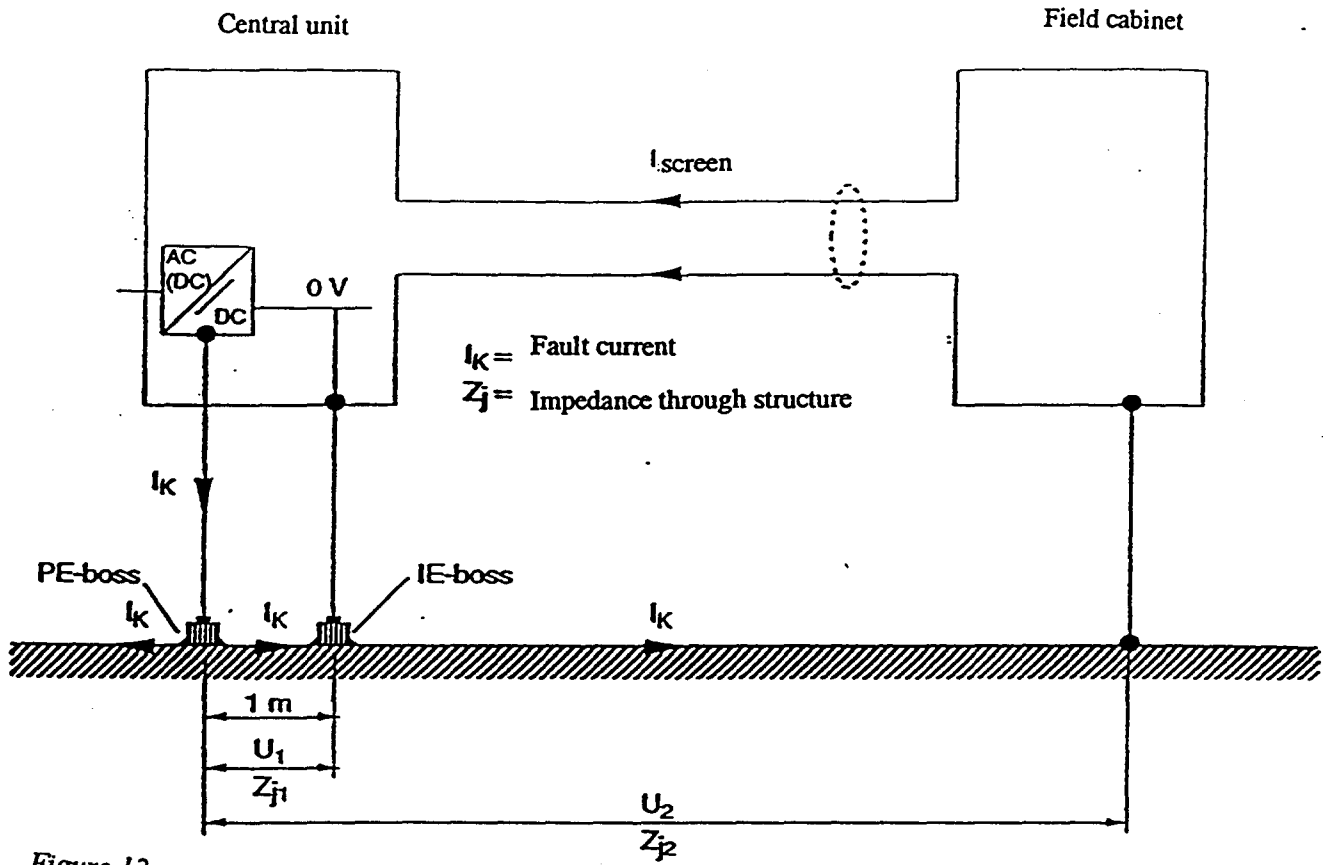
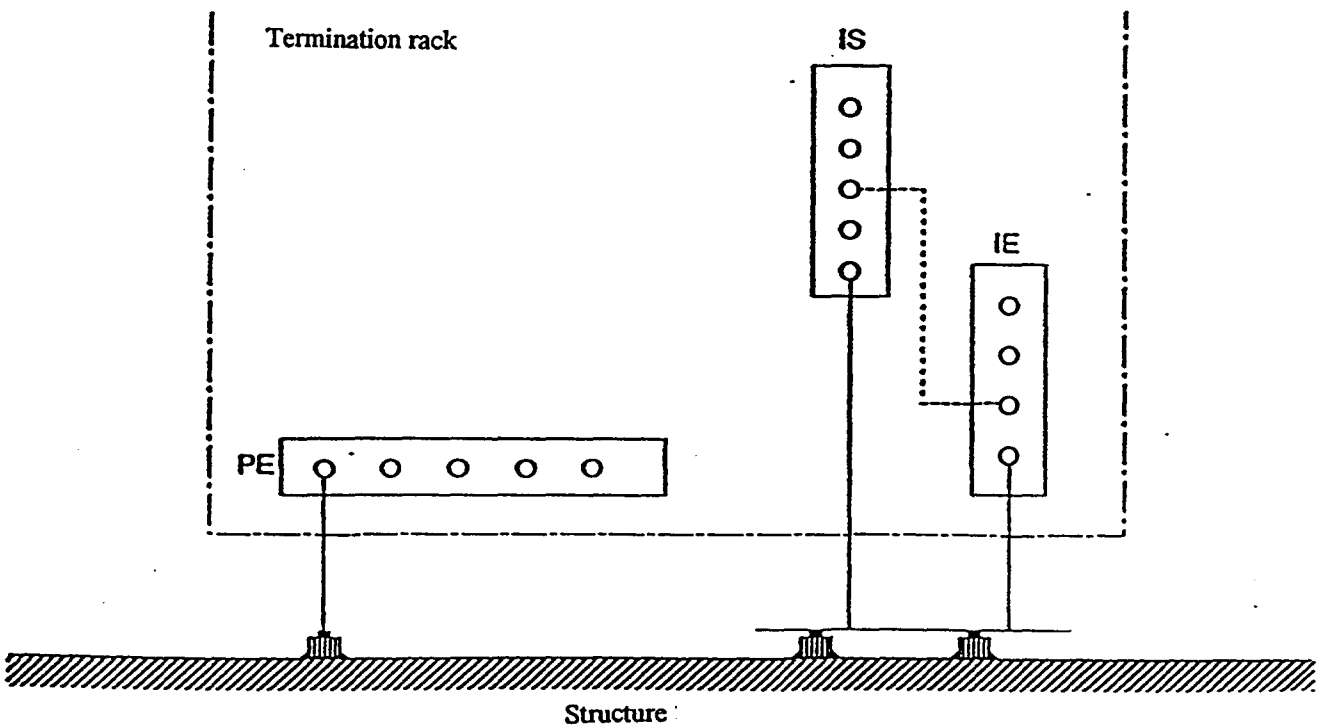

Figure 12

Instrument earthing at central unit (termination rack)



Alternatively "IS" and "IE" may be interconnected.
The connection from "IS" to structure may then be deleted.

Figure 13

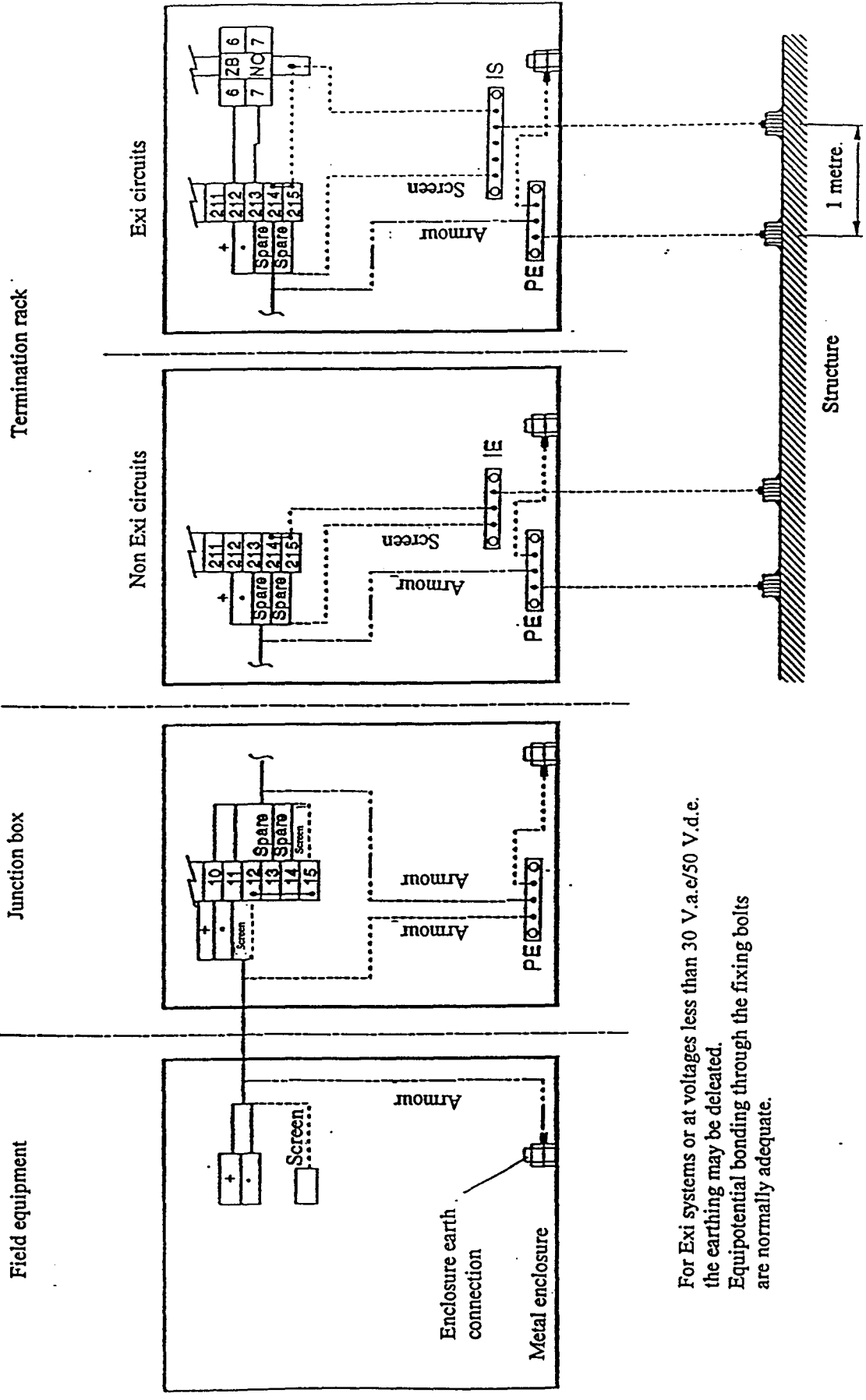

For Exi systems or at voltages less than 30 V.a.c./50 V.d.e. the earthing may be deleted. Equipotential bonding through the fixing bolts are normally adequate.

Figure 14

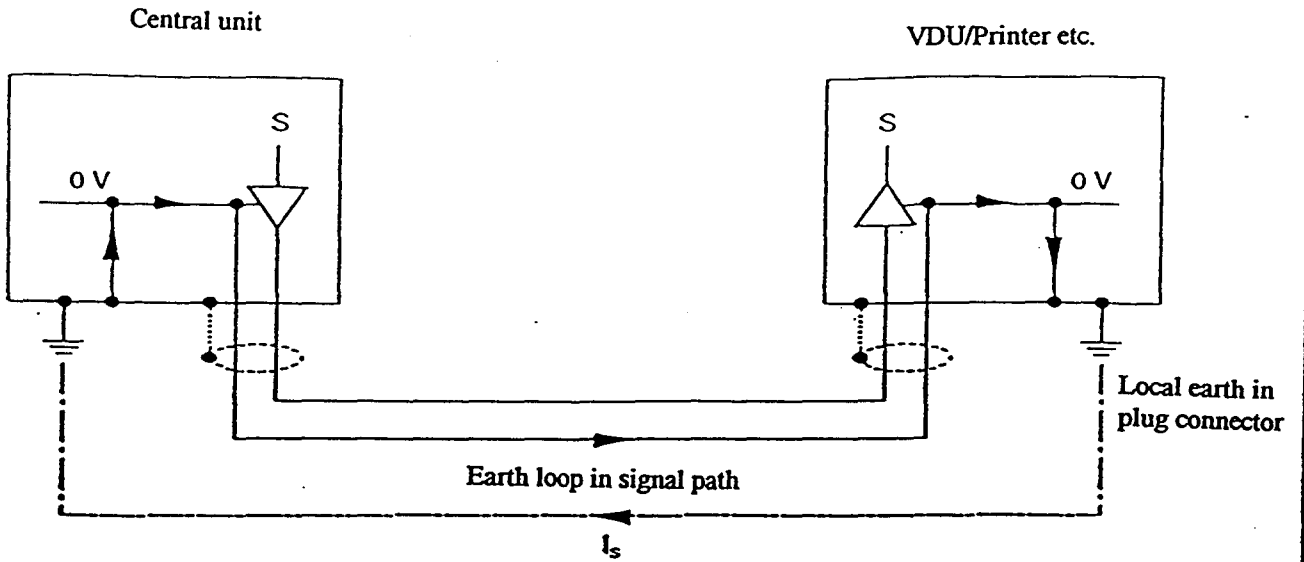

Figure 15

Noise current due to the noise in the loop

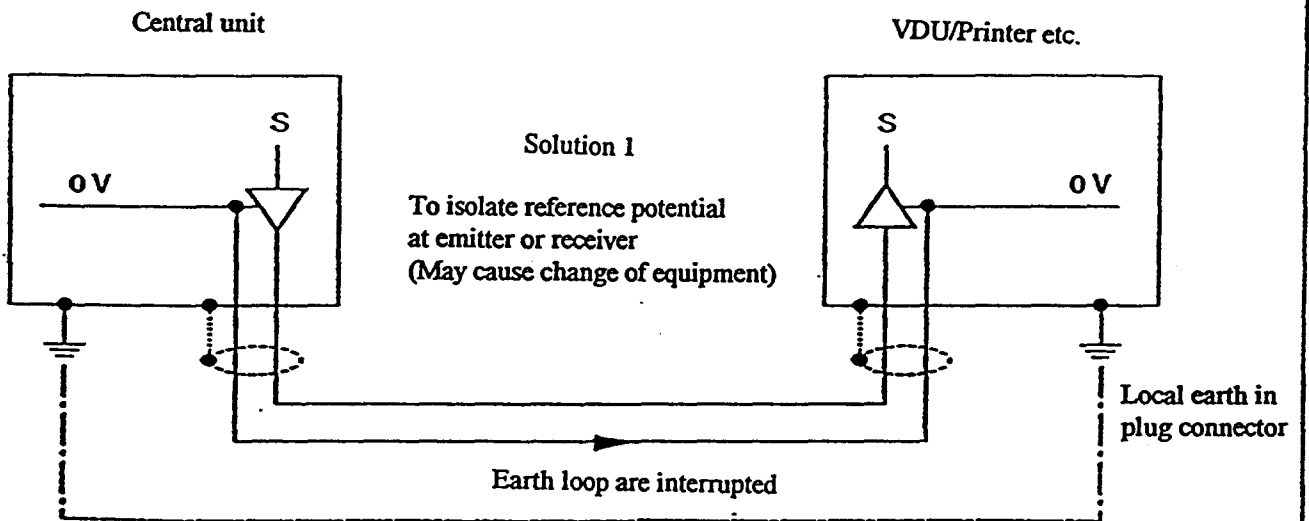

Figure 16

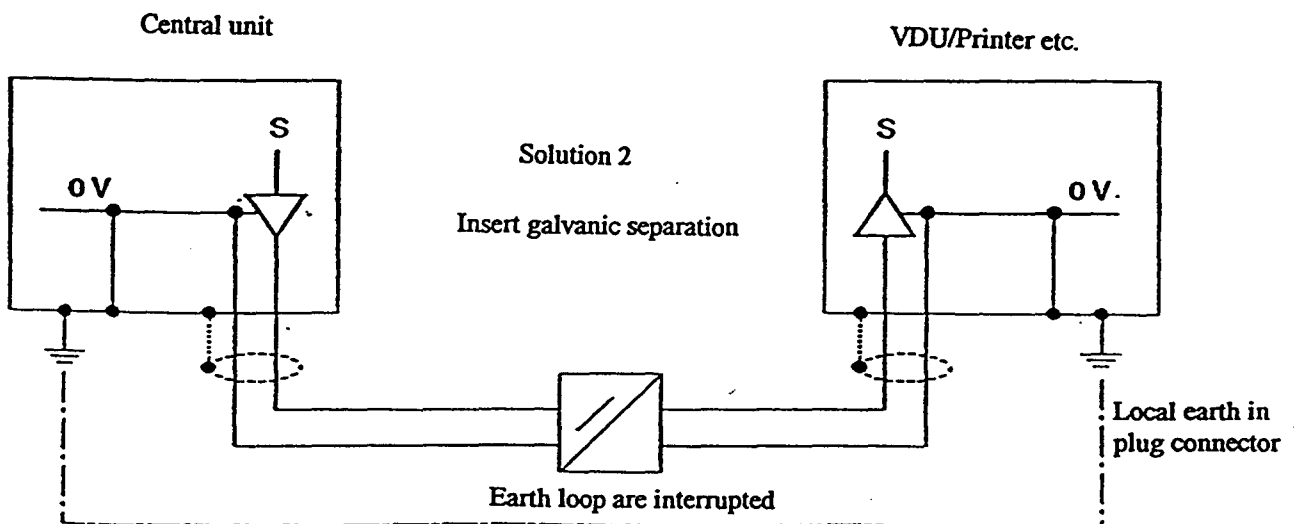
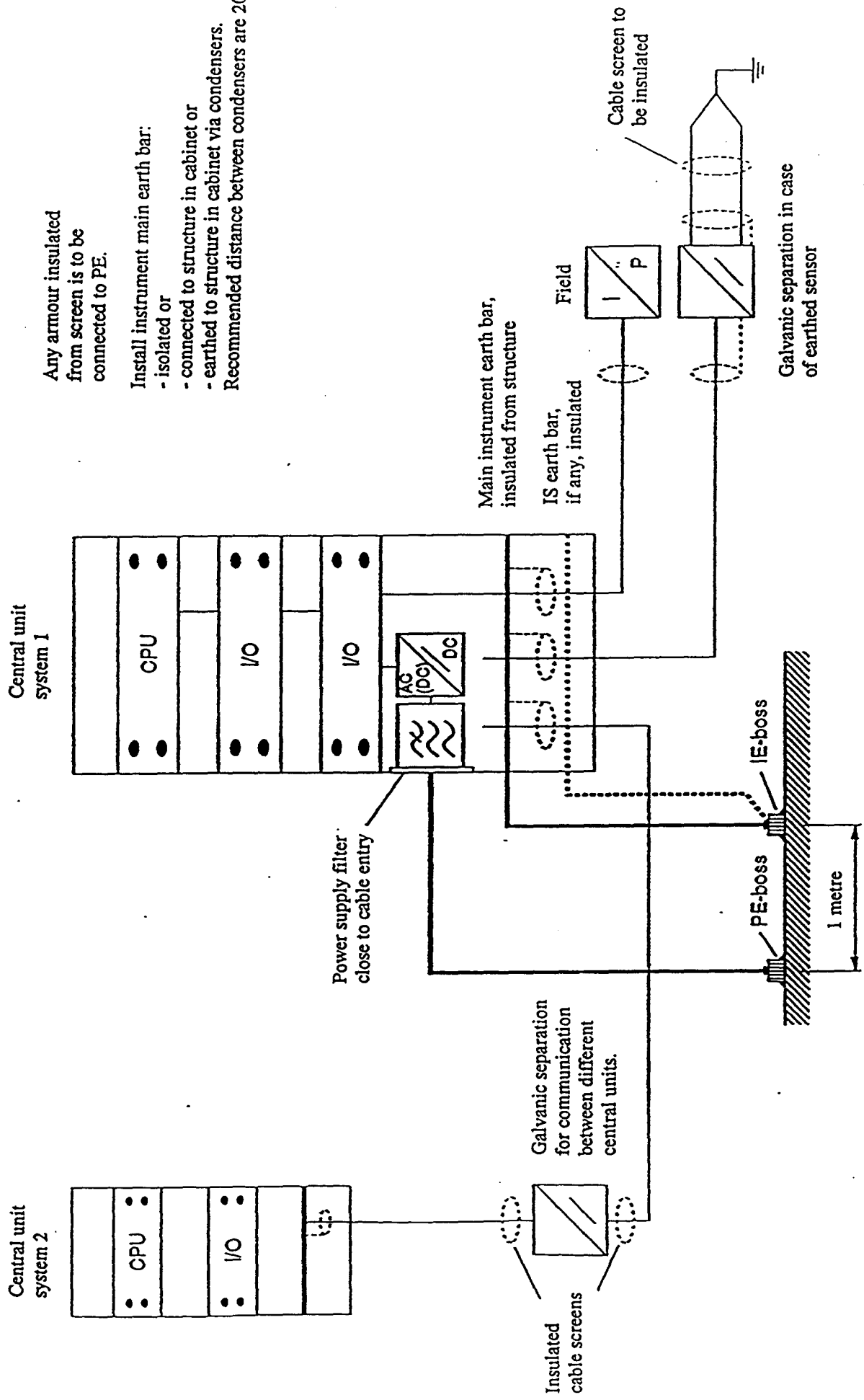

Figure 17

Earthing in instrumentation systems



Any armour insulated from screen is to be connected to PE.

Install instrument main earth bar:

- isolated or
- connected to structure in cabinet or
- earthed to structure in cabinet via condensers.

Recommended distance between condensers are 20 cm.

Figure 18

Cable gland with extended earthing cone

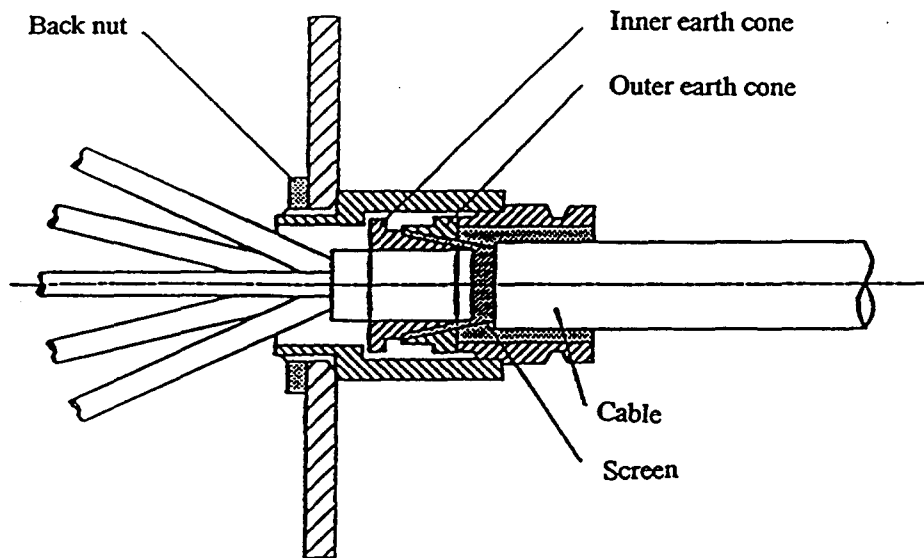

Cable with extended earth cone

The gland does not have an outer seal. Moisture protection by means of Sikaflex or heat shrink sleeve may be required.

Figure 19

Cable shale for connection to cable screen

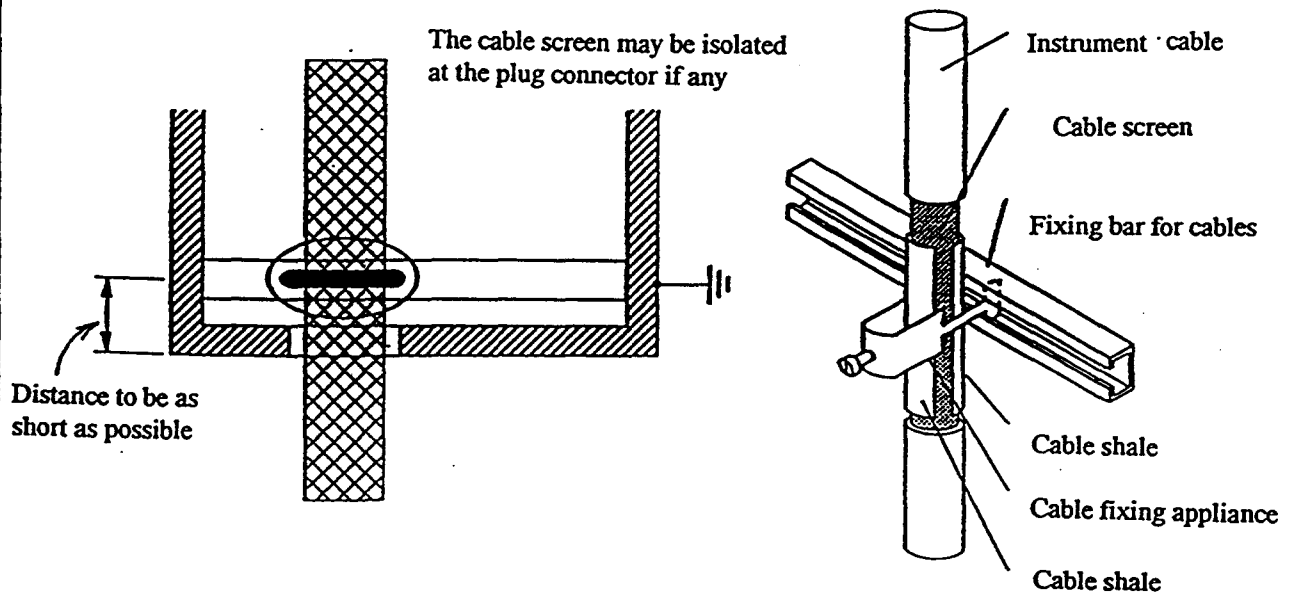

Figure 20

Cable screen connector up to 20 mm diameter

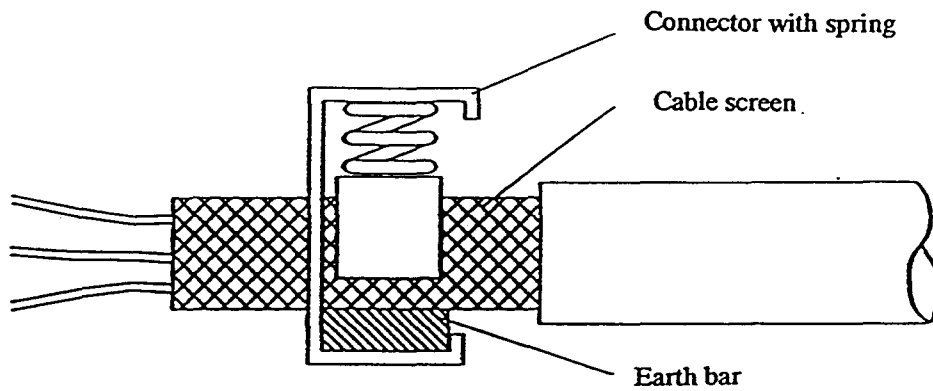
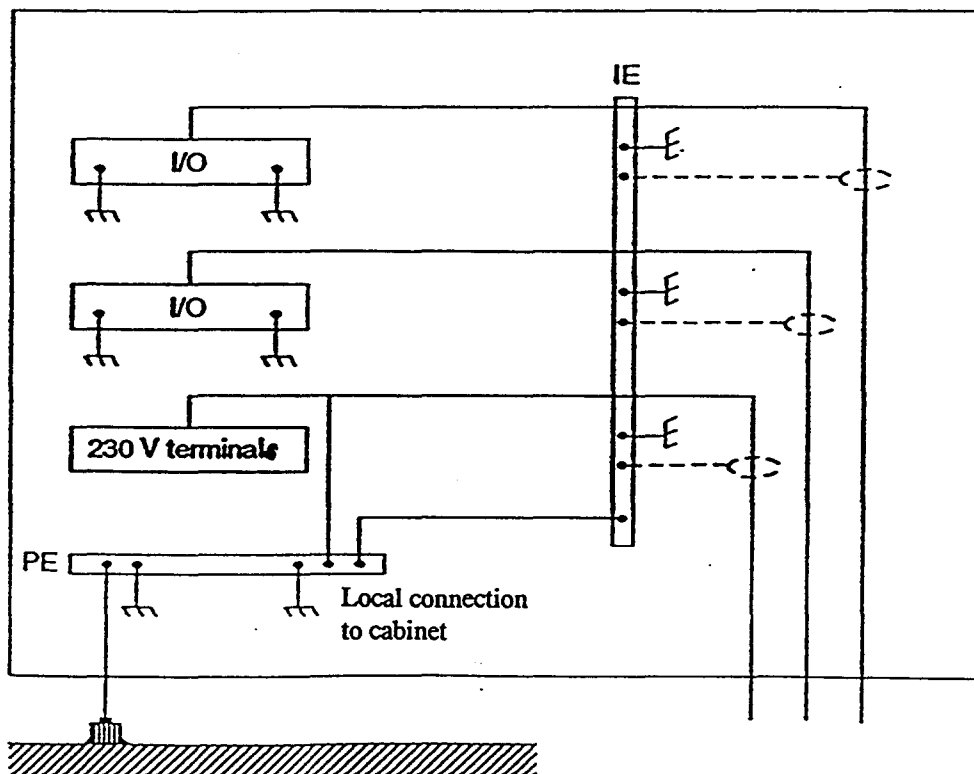

Figure 21



PE and IE bar to be connected locally to cabinet
I/O equipment to be connected locally to cabinet

Figure 22

EMC-MCT with brass plates

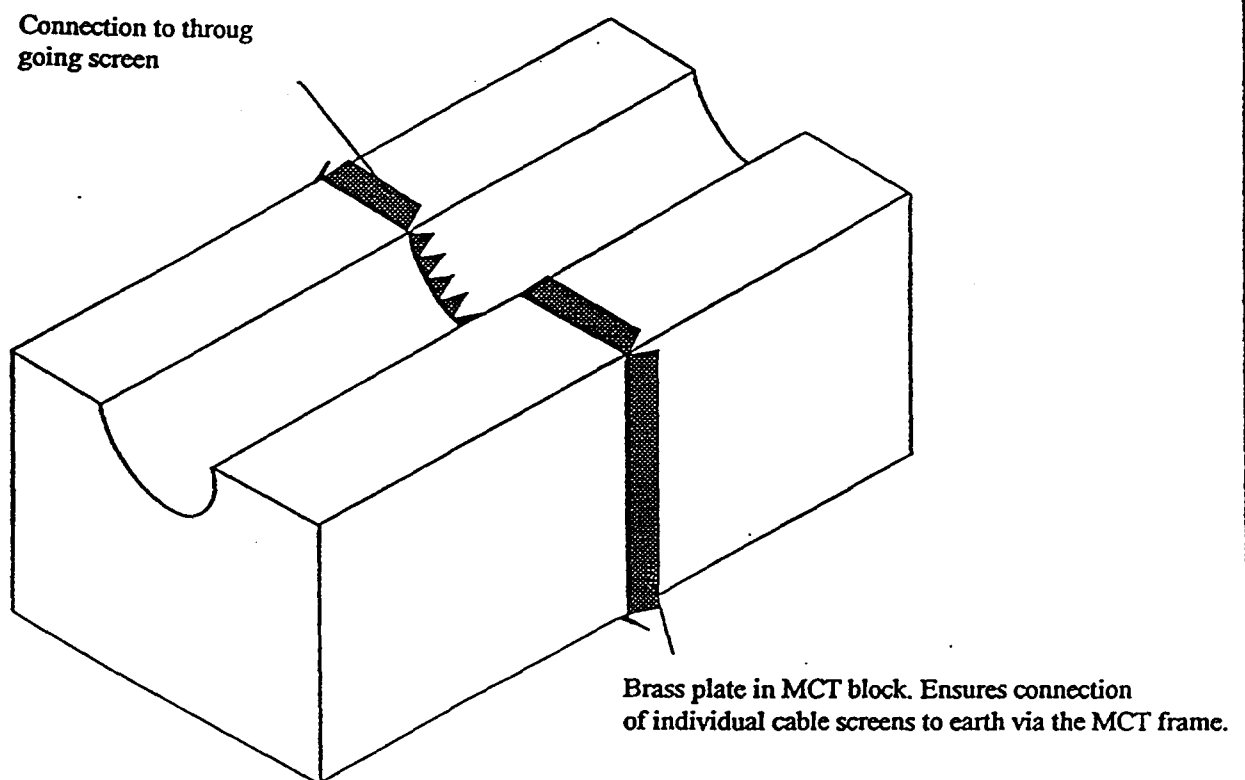

Figure 23

Earthing in explosion hazardous areas

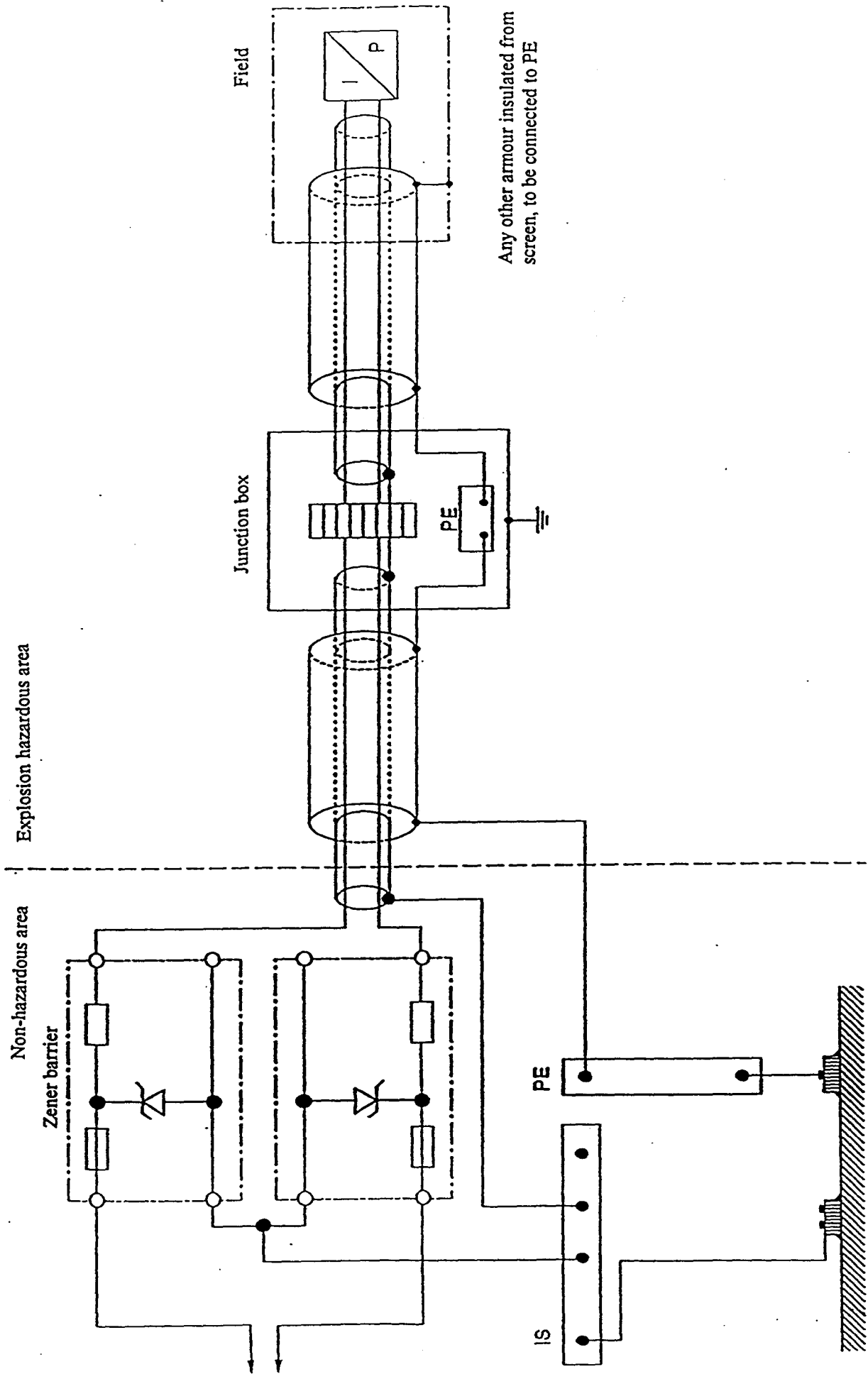

Figure 24

ENCLOSURE NO. 1

MEASURING EARTHING RESISTANCE

For measurement of the earthing resistance at power frequency it is recommended to use a DC ohm meter. The smallest range should be less than 1 mOhm, at a current of several Ampere. Separate terminals for voltage and current measuring wires are required. The DC measurements will normally give an acceptable indication of the resistance at 50 and 60 Hz, but is not representative for the properties at higher frequencies.

Due to a large cross sectional area the structure may be used as a return path for the current. For AC, the current distribution and thus the resistance is depending of the frequency and the location of the supply conductor. The resistance at power frequency is always greater than the DC resistance, but of the same magnitude. At 500 Hz, the resistance may be 10 times greater.

The following measurements should be considered:

- the resistance between two components, e.g a motor and its fundament.
- between two points at a distance

The latter measurement may be used to check larger parts of the installation.

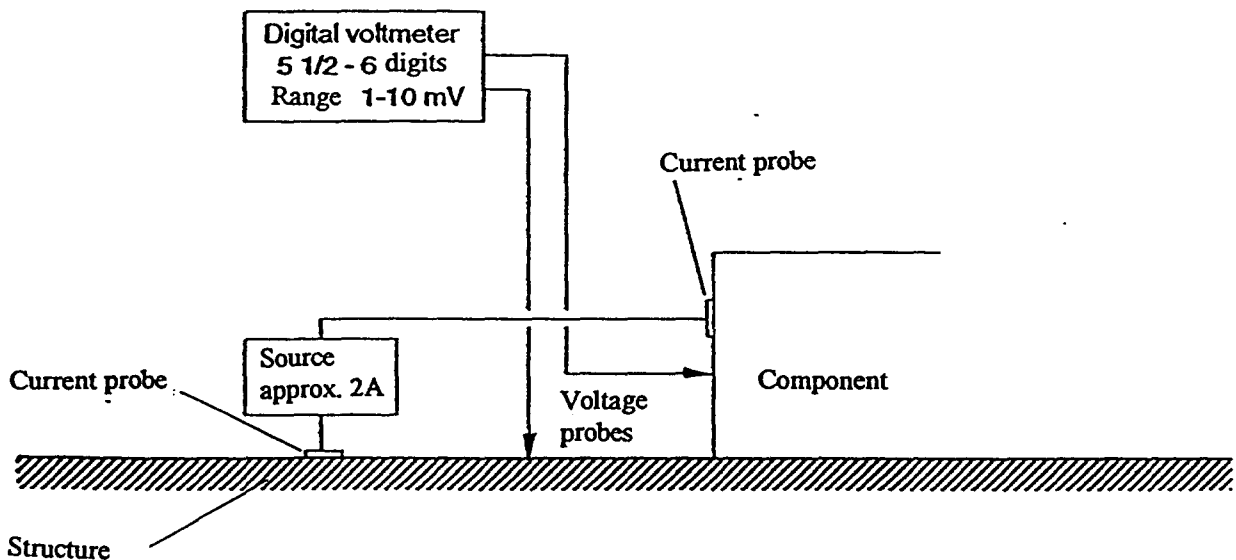

ENCLOSURE NO. 2

PROTECTION AGAINST LIGHTNING

Normally, it is not considered necessary to protect steel and metal enclosures by means of lightning arrestors. In order to limit local damage and voltage drop welded, or bolted connection between the various parts of the structure has to be used. Where lightning current can be expected to do local damage, short copper connectors should be used.

In constructions of armoured concrete good overlap between the armour bar has to be arranged, and the armour bar are to be kept together with e.g. steel wire. Welded or bolted connections are to be used between the steel structure and the armour bars.

Local lightning arrestors may be required for the protection of exposed equipment and personnel.

Due to electrical and thermal reasons the cross sectional area of lightning arrestor and associated conductors are to be at least 50 mm^2 copper. For carbon steel and aluminium the minimum cross sectional area is at least 100 mm^2 . Separate earthing boss, welded to the structure should be used.

ENCLOSURE NO. 3
REFERENCES AND DEFINITIONS

1. References

1.1 Regulations for electrical installations in the petroleum activity

Stipulated by the Norwegian Petroleum Directorate 8 January 1991

1.2 Law of 24 May 1924 regarding Supervision of electrical installations

1.3 Regulations for Electrical Installations - Maritime Installations (FEA-M)

Stipulated by NVE 1 March 1990

1.4 Regulations for Electrical Installations in Buildings (FEB)

Stipulated by NVE 20 December 1989

Section 808 of the regulations apply to processing plants in the offshore industry

2. Definitions

2.1 Main earth. Definition according to FEA-M p 1114.1, slightly modified.

2.2 Main earthing bar, main earth terminal. Definition according to FEA-M p 1114.6, slightly modified

2.3 Main earthing conductor. Definition according to FEA-M p 1114.5

2.4 Protective earth connections. Definition in accordance with FEA-M p 1114.3, slightly modified

2.5 Protective conductor. Definition in accordance with FEA-M p 1114.4

2.6 Equipotential bonding. Definition in accordance with FEA-M p.1114.9

ENCLOSURE NO. 4
ABBREVIATIONS

FEA-M	Regulations for Electrical Installations - Maritime Installations
FEB	Regulations for Electrical Installations in Buildings
PE	Protective Earth
EMC	Electromagnetic Compatibility
LF	Low frequency, below 10 kHz
HF	High frequency, above 10 2 kHz
VHF	Very High frequency, from 1 MHz to 30 MHz